

4 Channel Coarse Wavelength Division Multiplexer

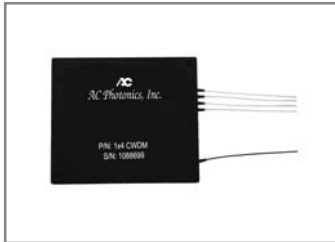

ACP's Coarse Wavelength Division Multiplexer (CWDM) utilizes thin film coating technology and proprietary design of non-flux metal bonding micro optics packaging. It provides low insertion loss, high channel isolation, wide pass band, low temperature sensitivity and epoxy free optical path .

All AC Photonics' products are Telcordia qualification tested.

Key Features

- Low Insertion Loss
- Wide Pass Band
- High Channel Isolation
- High Stability and Reliability
- Epoxy Free Optical Path

Applications

- Line Monitoring
- WDM Network
- Telecommunication
- Cellular Application
- Fiber Optical Amplifier
- Access Network

Performance Specifications

Parameter	Specifications	
	Mux	Demux
Operating Wavelength	Full Band (FB): 1270nm to 1610nm;	
	Standard: 1270nm to 1350nm or 1430nm to 1610nm	
Center Wavelength	1270nm, 1290nm, ..., 1610nm or 1271nm, 1291nm,1611nm	
Center Wavelength Accuracy	± 0.5nm	
Channel Spacing	20GHz	
Channel Passband (@-0.5dB bandwidth)	≥ 13nm	
Insertion Loss	≤ 1.4dB	≤ 1.4dB
Channel Uniformity	≤ 0.6dB	≤ 0.6dB
Channel Ripple	≤ 0.3dB	≤ 0.3dB
Isolation @Add/Drop Channel	Adjacent	≥ 30dB
	Non-adjacent	≥ 40dB
Insertion Loss Temperature Sensitivity	≤ 0.003dB/°C	
Wavelength Temperature Shifting	≤ 0.002nm/°C	
Polarization Dependent Loss	≤ 0.10dB	
Polarization Mode Dispersion	≤ 0.10ps	
Directivity	≥ 50dB	
Return Loss	≥ 45dB	
Optical Power	≤ 300mW	
Operating Temperature	0 to +70°C	
Storage Temperature	-40 to +85°C	
Package Dimensions	L96nm x W78nm x H8.0nm	

Mechanical Dimensions

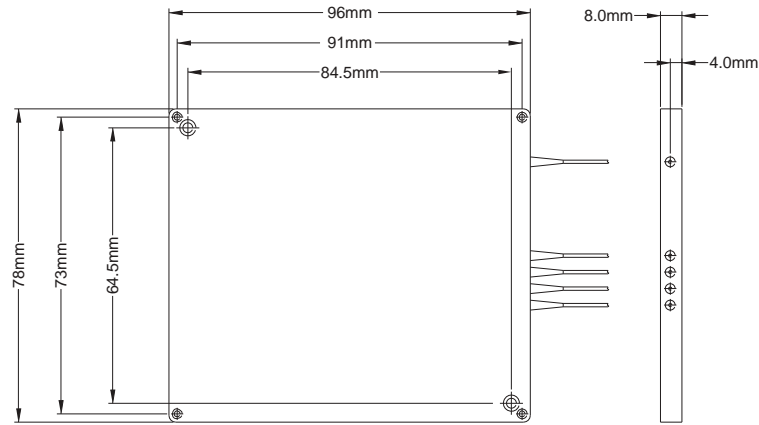

Ordering Information

CWDM	<input type="text"/>	<input type="text"/> <input type="text"/>	<input type="text"/>	<input type="text"/> <input type="text"/> <input type="text"/>	<input type="text"/>	<input type="text"/>	<input type="text"/> <input type="text"/>	<input type="text"/> <input type="text"/>
	Channel Spacing	Number of Channel	Configuration	1st Channel	Pigtail Style	Fiber Length	In/Out Connector	FB
	C = CWDM Grid	04 = 4 Channel	M = Mux D = Demux	470 = 1470nm 471 = 1471nm 551 = 1551nm 571 = 1571nm	1 = Bare Fiber 2 = 900um Jacket 3 = 3mm Cable 4 = 2mm Cable	1 = 1.0m 2 = 2.0m	0 = None 1 = FC/APC 2 = FC/PC 3 = SC/APC 4 = SC/PC 5 = ST 6 = LC/UPC 7 = LC/APC	FB = Full Band Leave Empty = Standard